

HD9

chassis 4x2 42.38 / 42.42 / 42.44 / 42.48

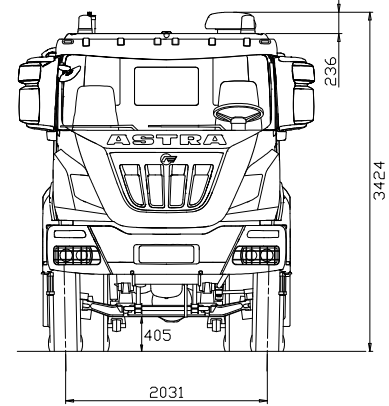
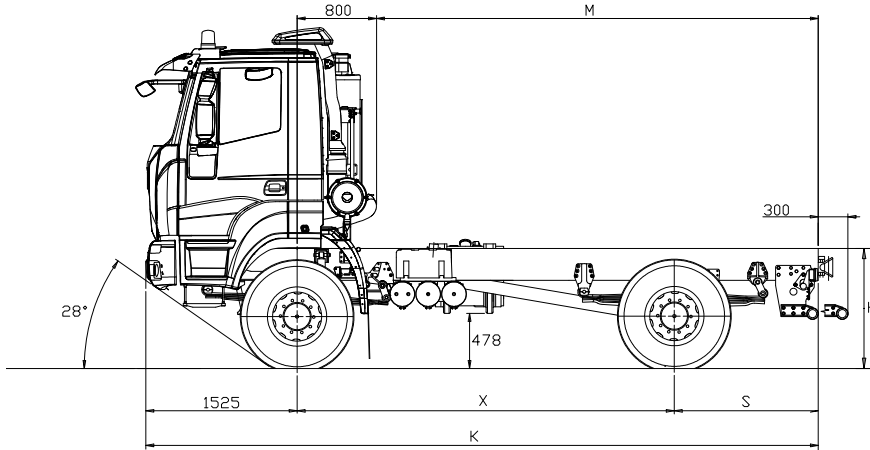

DIMENSIONS (mm)

X	K	M max (*)	S	H		TURNING DIAMETER (wall to wall)
				unloaded	loaded	
3800	6775	4450	1450	1150	1108	15500
4200	7575	5250	1850			16700
4600	8375	6050	2250			18000
5100	8875	6550	2250			19500

(*) M max.: indicative value to be confirmed by bodybuilder.

(Tyres 315/80R22.5)



WEIGHT (kg)

X	Distribution net weight (*)			Max technical weight			
	1 st axle	2 nd axle	Net weight	1 st axle	2 nd axle	Gross Vehicle Weight	Gross Combination Weight
3800	4920	2361	7281	8000 9000 (1)	13000	21000	55000
4200	4914	2415	7329				
4600	4922	2491	7413				
5100	4959	2509	7468				

(*) Weight including oil, fuel, spare wheel, driver Kg.75, with 315/80R22.5 tyres.

(1) With tyres on front axles 385/65R22.5 or 325/95R24 and reinforced springs (OPT).

Higher speeds are allowed with load reductions subject to Astra technical office approval.

Other tyres available, subject to Astra technical office approval.



ENGINES

CURSOR 13 turbo intercooler euro 3 diesel injection/cycle with electronic unit injection pumps. Single block head, four valves per cylinder, light alloy pistons. Total displacement: 12.882 cm³. Bore for stroke: 135 x 150 mm. 6 in-line cylinders. Water cooling. Viscostatic cooling fan. Dry air filter with safety cartridge. Vertical muffler.

	42.38	42.42	42.44	42.48
Model	CURSOR 13	CURSOR 13	CURSOR 13	CURSOR 13
Max power (EEC)	280 kW (380 HP)	309 kW (420 HP)	324 kW (440 HP)	353 kW (480 HP)
Corresponding rpm	1.900 rpm			
Max torque (EEC)	1.800 Nm (183 kgm)	1.900 Nm (194 kgm)	2.100 Nm (214 kgm)	2.200 Nm (224 kgm)
Corresponding rpm	1.000-1.440 rpm			
Turbine	WG Waste Gate		VGT Variable Geometry Turbine	



GEARBOX

Manual ZF Ecosplit 4 technology gearbox with servoshift, 16 synchronised forward speeds + 2 reverse:

ZF16S2220TO: HD9 42.38 / HD9 42.42 / HD9 42.44

ZF16S2520TO: HD9 42.48

On request:

ZF16S2320TD: HD9 42.38 / HD9 42.42 / HD9 42.44 / HD9 42.48

ZF ASTRONIC 16AS2630TO: HD9 42.42 / HD9 42.44 / HD9 42.48

		Speed [kph] calculated at maximum power rpm																		
		Gears																		
		1	2	3	4	5	6	7	8	9	10	11	12	13	14	15	16	RM1	RM2	
ZF 16S2220TO ZF 16S2520TO	Gear ratios	13.80	11.54	9.49	7.93	6.53	5.46	4.57	3.82	3.02	2.53	2.08	1.74	1.43	1.20	1.00	0.84	12.92	10.80	
	Rear axle ratio	3.793	7.5	8.9	10.9	13.0	15.8	18.9	22.5	27.0	34.1	40.7	49.5	59.2	72.0	85.9	103.0*	122.7*	8.0	9.5
		4.229	6.7	8.0	9.7	11.7	14.2	16.9	20.2	24.2	30.6	36.5	44.4	53.1	64.6	77.0	92.4*	110.0*	7.2	8.6
		5.009	5.7	6.8	8.2	9.8	11.9	14.3	17.1	20.4	25.8	30.8	37.5	44.8	54.6	65.0	78.0	92.9*	6.0	7.2
		5.558	5.1	6.1	7.4	8.9	10.8	12.9	15.4	18.4	23.3	27.8	33.8	40.4	49.2	58.6	70.3	83.7	5.4	6.5
		6.095	4.6	5.6	6.8	8.1	9.8	11.7	14.0	16.8	21.2	25.3	30.8	36.8	44.8	53.4	64.1	76.3	5.0	5.9
6.588	4.3	5.1	6.3	7.5	9.1	10.9	13.0	15.5	19.6	23.4	28.5	34.1	41.5	49.4	59.3	70.6	4.6	5.5		
ZF16S2320TD	Gear ratios	16.41	13.80	11.28	9.49	7.76	6.53	5.43	4.57	3.59	3.02	2.47	2.08	1.70	1.43	1.19	1.00	15.36	12.92	
	Rear axle ratio	3.793	6.3	7.5	9.1	10.9	13.3	15.8	19.0	22.5	28.7	34.1	41.7	49.5	60.6	72.0	86.6	103.0*	6.7	8.0
		4.229	5.6	6.7	8.2	9.7	11.9	14.2	17.0	20.2	25.7	30.6	37.4	44.4	54.4	64.6	77.7	92.4*	6.0	7.2
		5.009	4.8	5.7	6.9	8.2	10.1	11.9	14.4	17.1	21.7	25.8	31.6	37.5	45.9	54.6	65.6	78.0	5.1	6.0
		5.558	4.3	5.1	6.2	7.4	9.1	10.8	12.9	15.4	19.6	23.3	28.5	33.8	41.4	49.2	59.1	70.3	4.6	5.4
		6.095	3.9	4.6	5.7	6.8	8.3	9.8	11.8	14.0	17.9	21.2	26.0	30.8	37.7	44.8	53.9	64.1	4.2	5.0
6.588	3.6	4.3	5.3	6.3	7.6	9.1	10.9	13.0	16.5	19.6	24.0	28.5	34.9	41.5	49.8	59.3	3.9	4.6		

(*) Max speed 90 km/h. Other speeds available, subject to the Astra technical office approval



P.T.O.

On request:

Gearbox	ZF16S2220TO-ZF16S2520TO	Mx. Torque	Application
P.T.O.	Ratio	Nm	
ZF NH/1b	0.91/1.09:1	1000	For tipping unit pumps, pumps for cranes, ecc.
ZF NH/1c	0.91/1.09:1	1000	For tipping unit pumps, unit pumps for concrete, pumps for cranes, ecc.
ZF NH/4c	1.17/1.40:1	430	For tipping unit pumps, ecc.
ZF N221/10B-PL + NL/1c	1.75/2.09:1+0.91/1.09:1	560+600	Double PTO for concrete pumps

Power take-off Multipower (ratio 1.29:1) max available torque 900 Nm for concrete mixers.



CLUTCH

Single dry plate, diameter 17". Pull type engagement with diaphragm spring.

Hydro-pneumatic power steering engagement control, with driven disc wear recovery slave cylinder.

On request:

Ceramic clutch 17"



AXLES

Steering, hot moulding in high tensile steel.

REAR

Driving axle with double reduction: central with bevel gear, final by planetary gear in wheel hubs. Cross-axle differential lock.

On request:

Rear-axle ratio 1:3.793

Rear-axle ratio 1:4.229

Rear-axle ratio 1:5.009

Rear-axle ratio 1:5.558

Rear-axle ratio 1:6.095

Rear-axle ratio 1:6.588



SUSPENSIONS

FRONT

1st axle, parabolic springs, 4 leaves 24x90 mm, with hydraulic shock absorbers.

Standard stabilizer bar.

On request:

Reinforced parabolic springs, 5 leaves 24x90 mm.

(Mandatory with 9t version).

REAR

Parabolic springs, 4 leaves 24x90 mm + 1 leaf 50x90 mm, with hydraulic shock absorbers.

Standard stabilizer bar.



CHASSIS

Special steel with high tensile strength limit, two flat and parallel side members (width 820 mm.), C section (320x70x8 mm), cross members bolted to the frame.

R.B.M. (Rail Bending Moment): 143.149 Nm (14.597 Kgm.).

Steel front bumpers with headlamp protection grids, front manoeuvring hook, rear underrun bar, steel fuel tank capacity 300 litres.

On request:

Rapid pneumatic connection for tyre inflation.

Rear manoeuvring hook.

Rear automatic towing hook.

Rubber mudguards on 2nd axle.

Front bumper climbing step.

Side winch for spare wheel.



TYRES

FRONT: 315/80R22.5 156/150 K Single tubeless

REAR: 315/80R22.5 156/150 K Twin tubeless

Spare wheel on the chassis.

Other Possible combinations:

TYRES	ASSEMBLY	
	FRONT	REAR
12.00 R20 156/150G	S	D
13 R22.5 156/150K		
385/65 R22.5 160J (*)	S	
315/80 R22.5 156/150K		D
325/95R24 162/160K (*)	S	D
12.00R24 160/156G (*)		

S single

D double

Other tyres available, subject to the Astra technical office approval.

(*) Mandatory with 9t front axle load.



PNEUMATIC SYSTEM

Two-cylinder 630 cc compressor, APU (Air Processing Unit) that includes: regulation valve set at 10.3 bar, drier, 4-way safety valve, pressure reduction valve for parking circuit and services. 3 air tanks, capacity 30 litres.

ABS system and EBL (Electronic Brake Limiter).



BRAKES

Front and rear drum brakes, Duo-Duplex with automatic slack adjuster. ABS + EBL system.

Service brake: Pedal controlled air brake, acting on all wheels.

Solo vehicles: two independent circuits, one for 1st axle, one for 2nd axle.

Towing vehicles: three independent circuits, one for 1st axle, one for 2nd axle and another for the trailer.

Emergency brake: Integrated in service brake.

Parking brake: Mechanical spring-type with pneumatic control acting on 2nd axle wheels.

IVECO BRAKE TURBO engine brake:

HD9 380/420 HP braking power 255 kW (342 HP).

HD9 440/480 HP braking power 300 kW (402 HP).

On request:

Hydraulic interarder (only for AS-Tronic gearbox).

1st axle immobiliser system.

OFF/ROAD button for excluding ABS for speed < 15 kph.



STEERING

ZF 8098 quadrilateral power steering on front axle wheels with variable ratio 1:22.2/1:26.2 with auxiliary cylinder. Circuit with main hydraulic pump on engine and emergency pump on gearbox. Steering rods with self-lubricating joints. Height and inclination mechanical adjustable steering wheel.



SERVICE DATA(I)

Engine oil sump and filters	28 (+2.5)
Gearbox oil	14.5
Power steering oil	8.5
Cab tipping oil	1
Clutch circuit oil	0.5
Integral PTO oil.....	3
Rear axle with final red. oil	16
Cooling system water	33
Diesel	300



ELECTRICAL SYSTEM

Voltage: 24 V

Alternator generator 90 A - 28 V (2520 W).

Accumulators: 2 in series, 170 Ah.

Starter motor 24 V 5.5 kW.

Mechanically controlled electrical circuit breaker.

Anti-block system ABS with 4-conduits and 4-electric valves electronic system.

1 electrical joint 7-pole (ISO 7638) for trailer ABS (if applicable).

1 electrical joint 15-pole (ISO 12089-4091) for trailer lighting (if applicable).

Electrical provision for outfitters.

Provision for diagnostics.

Provision for radio/cb (without speakers).

Glow plug for cold start.

On request:

225 Ah accumulators;

Reverse alarm.



CAB

Standard white short cab (AD built in galvanized pressed steel with hydraulic tilting up to 60°. Cab suspension with 4 helicoidal springs with coaxial shock absorbers and integrated dampers, anti-roll bar and end-of-stroke pads. Tinted electric door windows.

Mechanical rear view mirrors, wide angle mirrors and front view mirror. Internal panels completely washable and fireproof.

Compressed air quick coupling for cab cleaning. 4-speed ventilation and heating system with air recirculation system.

Air suspended 3-way adjustable driver seat with seat belts.

Mechanical passenger seat with seat belts.

On request:

RHD.

Air conditioning with anti-pollen filter.

Cab rear window.

Car radio RDS, CD.

Car radio RDS, CD, MP3 Bluetooth technology.

External sun visor.

Extra colour cab: to be specified in the order.

Heated and electric powered rear view mirrors.

Remote controlled and centralized closing of doors.

Roof hatch.

Rotating lights on top of the cab.

White engine hood with central mask in IC575 colour.



INSTRUMENTATION

Dashboard and ergonomic instrument board contain the function buttons and the identification commands.

Indicator lights: engine oil low pressure, alternator charging low, main beam lights, side lights, engine warm-up, rear fog light, hazard lights, tractor turn indicators, trailer turn indicators (if applicable), rotating lights, cab lifted, axles differential locked, differential lock, front brakes air pressure low, rear brakes air pressure low, trailer brakes air pressure low (if applicable), parking brake engaged, splitter (reduction on), slow speeds (1-4/9-12), power take-off on (if applicable) air filters clogged, power steering oil level low, rear view mirrors heated (if applicable), ABS, trailer ABS (if applicable), main steering circuit failure, steering auxiliary circuit failure.

ASTRA Veicoli Industriali

Via Caorsana, 79

29122 Piacenza (Italy)

Tel. +39-0523/54311

Fax +39-0523/591773

www.iveco-astra.com

DEALER

Characteristics and equipment are subject to changes without prior notice.

Technical data and general specifications - validity to be checked according to each individual configuration