



# MK28L-5"

## TRUCK-MIXER PUMP "MAGNUM" MK28L-5"-80/115 RH

Placing Boom	MK28L-5"
Pumping Unit	PB 607 S7, PB 808 S7
Concrete Mixer	RH 80-115
Driven by	PTO-Gear box by CIFA
Chassis	4 axles



### Dimensions

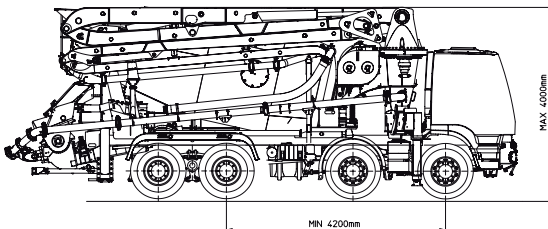

Dimensions varying according to truck assembly

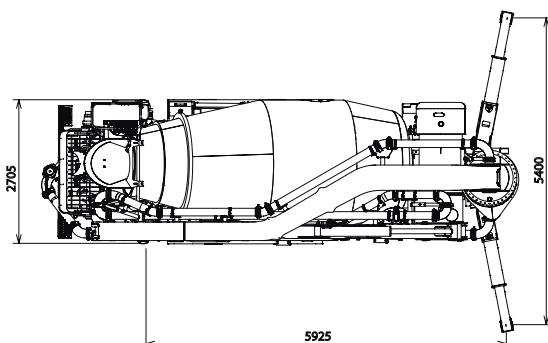

# MK28L-5"

## Standard equipment

- Compact and harmonic line, studied for assembling on 4 axles chassis
- Chassis at extremely high torsion absorption, calculated according to Finite Elemental Methods (FEM)
- Ideal load distribution on the axles to obtain better driving stability
- Outriggers fully hydraulic controlled on both machine sides with front telescopic double extension at automatic patented sequence and fixed rear outriggers.
- Great loading capacity drum with elliptic bottom, in high wear resistant steel of 30 MnB5
- Placing boom MK 28L, 4 sections, pipeline diameter 125 mm, "Z" folding system
- CIFA Pumping unit with 7" valve of high concrete suction performances and filling ratio, less wearing, improved and optimised shape to reduce wearing and diesel fuel consumption
- Proportional boom control
- "BFC" Best-Flex Cifa supporting system which allows quick, easy and safe pipeling changing by just one worker
- Concrete flow regulator
- Safety device at concrete discharging door opening
- Noiseless pumping with high performances: smooth, continuous and easy movements
- Two proportional radio remote control with two boom movement speed, synthesiser for automatic frequency search, 8 position joy stick and concrete flow rate regulator. 20 mt cable
- Two zinc-coated additional chutes, with supports for their fixing on counterframe
- Vibrator on the concrete hopper grid with remote control
- Centralized lubrication system for pumping unit
- Polymer rear mono-axle mudguards with rubber mudflaps
- Oil automatic lubrication system for pumping pistons
- Additional manual lubrication system for pumping unit
- Hard plastic outrigger support plates with relevant housing
- Light for pumping unit hopper
- Accessories for cleaning and washing
- Automatic adjustment sensor of truck-mixer discharge into hopper
- Concrete pipes with double thickness, in high wear resistant steel - CIFA Long Life Pipes
- Concrete pipes in double thickness with chrome carbide inserts in high wear resistant CIFA Long Life Hard (LLH)
- Long life wear plate and cutting ring with hard carbide inserts

## Control system

- Easytronic:
  - LCD monitor
  - Drum data
  - Pumping unit data
  - Working hours
  - Diagnostic

## Main Options

- Continuous boom rotation
- Cone-shaped discharging chute with end-cone dia. 200 mm
- Manual greasing system for rollers and rolling ring
- Automatic centralized greasing system for boom
- Emergency set of hydraulic pipeline
- Reversible chute
- "Ekos" dust exhausting device for drum closing
- LSC Stabilisation control system
- Aluminium hose/pipe holder on both sides with polymer rear mono-axle mudguards with rubber mudflaps

## TRUCK-MIXER PUMP "MAGNUM" MK28L-5"-80/115 RH

<b>Placing Boom</b>	MK28L-5"
<b>Pumping Unit</b>	PB 607 S7, PB 808 S7
<b>Concrete Mixer</b>	RH 80-115
<b>Driven by</b>	PTO-Gear box by CIFA
<b>Chassis</b>	4 axles

## Concrete Mixer Technical data

Model		80	115
Nominal capacity	<i>m<sup>3</sup></i>	7	9
Drum geometric volume	<i>m<sup>3</sup></i>	12,8	14,6
Filling ratio	%	55	69
Max. drum speed	<i>r.p.m.</i>	14	14
Water tank capacity	<i>l</i>	800	800
Water pump flow rate - Pressure	<i>l/min-bar</i>	230/15	230/15
Liter-counter scale	<i>l</i>	0-500	0-500

## Pumping unit technical data

Model		PB 607 S7	PB 808 S7
Max. theoretical output	<i>m<sup>3</sup>/h</i>	60	81
Max. pressure on concrete	<i>bar</i>	71	81
Max. number of cycles per minute	<i>n°</i>	32	43
Concrete cylinders (diam. x stroke)	<i>mm</i>	200x1000	200x1000
Concrete hopper capacity	<i>l</i>	400	500
"S" valve diameter	<i>"</i>	7	7

## Placing boom technical data

Model		MK 28L-5"
Pipeline diameter	<i>mm</i>	125
Max. vertical reach	<i>m</i>	28,1
Max. horizontal distance	<i>m</i>	24,1
Section numbers		4
1st section opening angle		90°
2nd section opening angle		185°
3rd section opening angle		253°
4th section opening angle		254°
Rotating angle		-240° / +240°
End hose length	<i>m</i>	4

Technical data and characteristics subject to modifications without notice