

PCS 209 D6

Description

The "CIFA SPRITZ SYSTEM" was born from innovative, modular and versatile technology which allows to solve in the best way every pumping operation linked to pumping and distribution of sprayed concrete, both in manual and automatic versions, as well as for underground and open-air works.

"PCS" Series portable pumps for the manual sprayed concrete distribution, designed, manufactured and guaranteed by the reliability and experience of Cifa systems.

Dimensions and performances diagrams

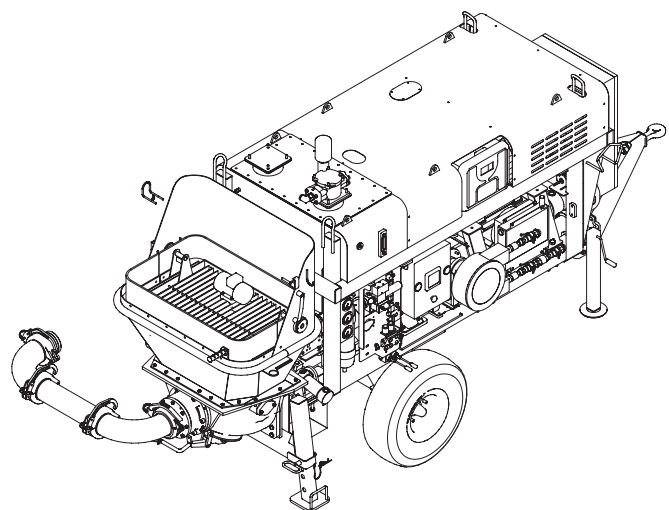
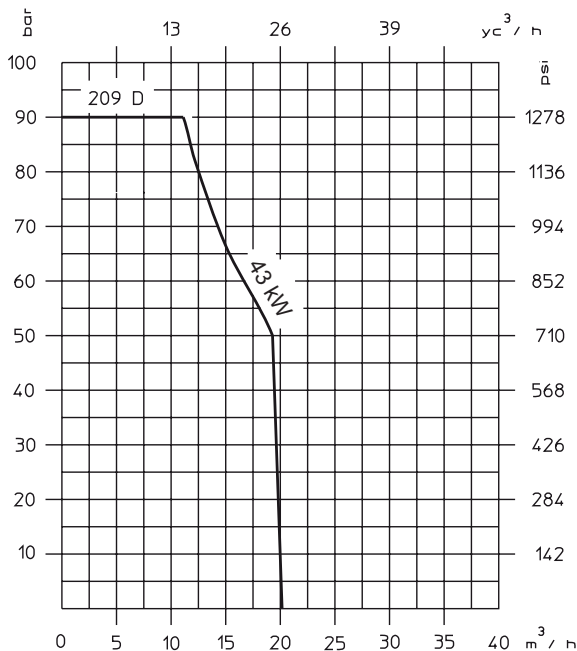
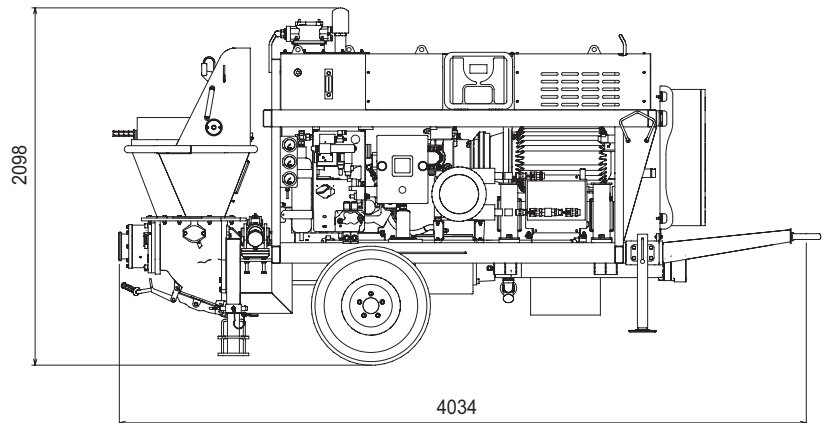
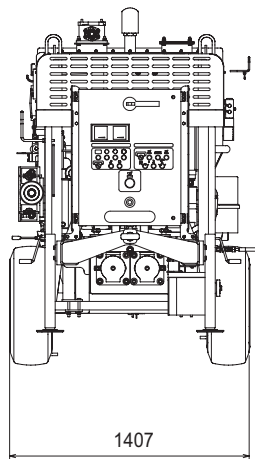

PCS 209 D6

Main features

Rigid monoaxle trailer complete of drawbar, four manual adjustable outriggers.

Suitable for transit on the job-site with a max. speed of 6 km/h. The unit is not prearranged for lights and brake system.

'S' valve in wear-resistant casting iron. A wear ring is mounted between the eye-plate and the valve for a perfect seal, assuring the stiff pumping of the sprayed concrete. CIFA system allows the automatic wear compensation of the ring, avoiding annoying and continuous adjustments.

The equipment is presetted to use the new proportional batcher 'Uniflux EAS', suitable for liquid accelerators.

The batcher is automatically connected with the sprayed concrete pumping system. Consequently, by varying the sprayed concrete output, the accelerators quantities are adjusted automatically, keeping the batching ratio pre-set by the operator.

- Transportability and practicability on the job-site
- Integration and flexibility
- Safety and ergonomy
- Quality and reliability of performances
- Low operating costs and scheduled maintenance

Standard equipment

- Motor Diesel Deutz 55 kW (Step 3B) or Perkins 44 kW (Step 3A)
- Rigid monoaxle trailer
- Drawbar
- Unit provided with automatic additive batching system 'Uniflux EAS'
- Hydraulically driven water pump (70 l/min - 20 bar)
- Quickjoint washing nozzle with 10m lenght hose
- Lubrication electric pump with proof tank 2000 cc.
- Power electric control panel according to IEC IP 55
- Electric vibrator on the hopper grid
- Accessories for piping washing and cleaning, two washing balls, connecting flange between water pipe and concrete piping
- Remote control with 20 m cable
- Concrete flow rate regulator
- Tool box + manual lubrication pump + set of tools
- 30 meters concrete flexible hoses kit with rigid reduction, joints, gaskets and safety pins; Air and additive flexible hose kit with fast connections and rigid joint.
- One colour painting, RAL 2000

Optionals

- Catalytic silencer
- Air-water cleaning stub pipe
- Kit Plastic tank for liquid additives, 1000 l capacity

TECHNICAL DATA

Manual sprayed concrete portable pump

Model		PCS 209
Drive power (Diesel)	<i>kW</i>	44 (3A) 55 (3B)
Concrete theoretical output	<i>m³/h</i>	0 - 20
Max. pressure on concrete	<i>bar</i>	90
Max. number of cycles per minutes		21
Concrete cylinders (diam. x stroke)	<i>mm</i>	176x1000
Concrete hopper capacity	<i>l</i>	300
Piston side drive		◆

Sprayed concrete equipment

Dosing System UNIFLUX EAS		
Pump output	<i>l/min</i>	2 - 17

NOZZLE		
Jet diameter	<i>mm</i>	35
Quickjoint (diam. 2')	<i>mm</i>	50

Technical data and characteristic subject to modifications